

(21) Application No 8038435
(22) Date of filing 1 Dec 1980
(30) Priority data
(31) 7941855
(32) 4 Dec 1979
(33) United Kingdom (GB)
(43) Application published
17 Jun 1981

(51) INT CL³
E05D 3/08 E05F 5/14
(52) Domestic classification
E2F 612 650 CB
E2X 1

(56) Documents cited
GB 1515875
GB 1482202
GB 1395390
GB 987750
GB 974498
GB 784280
GB 493335
GB 491872
GB 462865
GB 455281

(58) Field of search
E2F
E2X

(71) Applicant
Timber Research and
Development Association,
Stocking Lane,
Hughenden Valley, High
Wycombe,
Buckinghamshire

(72) Inventor
William John Bernard
Ollis

(74) Agent
Kilburn & Strode,
30, John Street, London,
WC1N 2DD

(54) Door Mounting

(57) A bottom hinge for a door mounting is formed with a plate (15) which is sunk into the threshold of a door frame and has a pair of arcuate grooves (14) one end of each of which constitutes a centre of a circular arc constituting the centre of the other

groove. On the underside of the door are a pair of elastomeric wheels (11), each of which can run along one of the grooves so that the door can open in either direction. There are provisions for latching the door in either open position; and fuseable means for allowing the door to close under its own weight in the event of a fire.

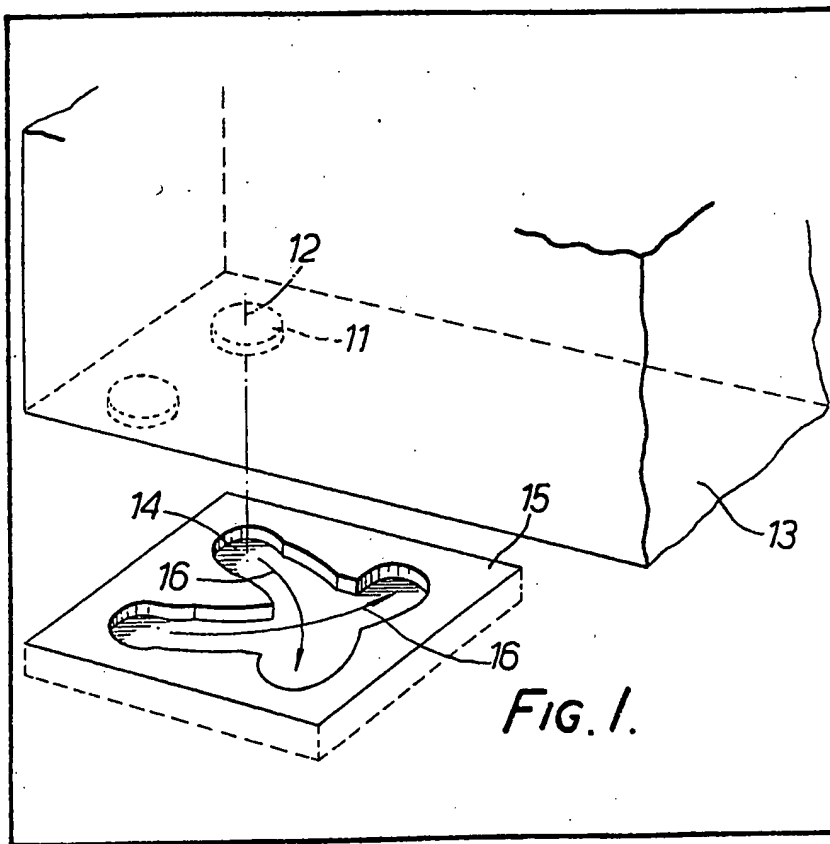

FIG. 1.

GB 2 064 642 A

1/1

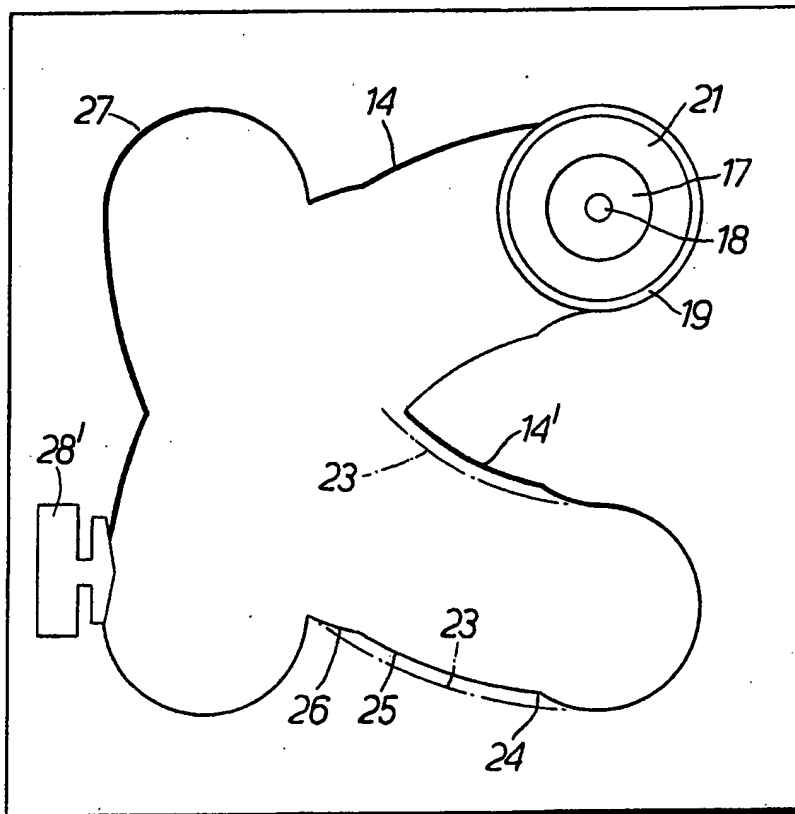
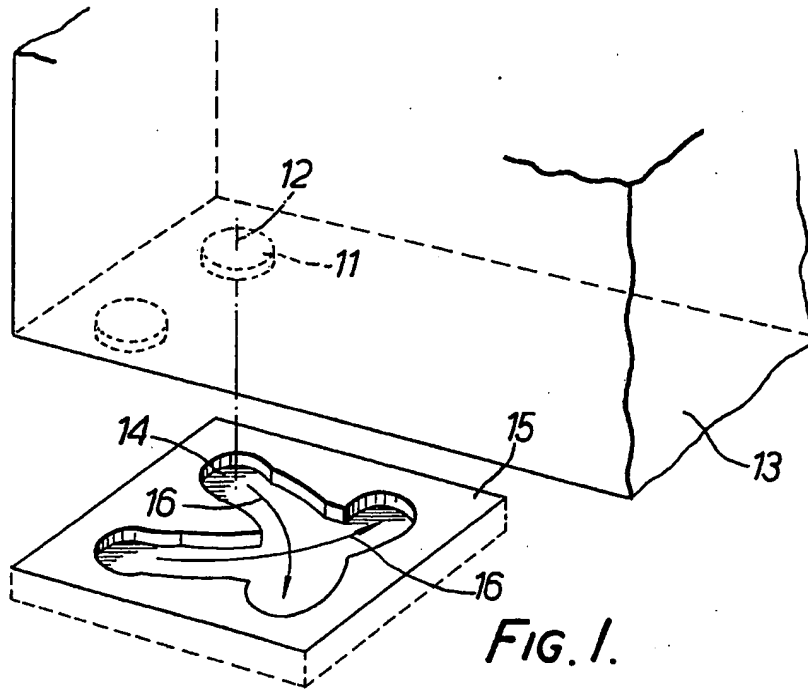

FIG. 2.

SPECIFICATION

Door Mounting

This invention relates to a hinge for a door mounting, and is an improvement in the invention the subject of British Patent Specification No. 1482202, published on the 10th August 1977.

That specification describes and claims a door mounting comprising top and bottom hinges each having a component for attachment to a door frame, the top hinge in use defining a single point through which any rotational axis of the door must pass, and the bottom hinge, defining in use two alternative hinge points in a horizontal plane, whereby the mounting defines two alternative hinge axes, extending through the single top hinge point and the respective bottom hinge points, and rotation of the door to one side of the vertical plane of the frame is about one of the hinge axes and rotation of the door to the other side is about the other hinge axis.

In the form shown in Figure 3 of the drawings, the bottom hinge components comprise one hinge member in the form of a plate having a pair of arcuate guides, each centered about a point in the other guide, and a second hinge member including a pair of pins each arranged to move along a different one of the guides during opening of the door in a different sense.

According to the present invention, a hinge for a door mounting comprises a plate having an arcuate guide, and a guide follower, one of which is arranged to be mounted one in relation to a door and the other in relation to a door frame the follower being at least partly of elastomeric material, and being of a size to need to be elastically deformed at certain parts of the guide.

In a preferred form of the invention, the plate has a pair of arcuate guides, each centered about a point on the other guide, and there are a pair of followers, each adapted to move along one guide while the other is located in relation to the other guide, and defines a hinge point, each of the followers being elastomeric as defined.

The mounting, the subject of Specification No. 1,482,202, was satisfactory in many ways, and provided a self-closing door. When the door was opened to either side, it pivoted about an axis through the single point at the top, and one or other of the alternative hinge axes at the bottom, such that in the open position, the weight of the door acted to one side of a vertical plane through the single point at the top, and the plane of the door frame to tend to restore the door to its centralised closed position.

One disadvantage was that in some circumstances, the door could be thrust open with considerable force and the pin could strike the end of the arcuate guide in the fully opened position, with sufficient force to damage the components. Also, the door could not be held in an open position without an external stop, and in the closed position it could be partly opened by a pressure difference on opposite sides.

The present invention overcomes these disadvantages, in that the resilience of the elastomeric material can cause each follower to act as a shock absorber, so that there is little likelihood of damage when a follower reaches the end of its guide. Again, the guide can be locally narrower, at the ends so that the follower requires to be deformed to move from the end of the guide and so a moderate force is required to start to open/or to start to close the door from either of the extreme positions. In that way, the door can be held open or closed.

The locally narrower portion of the arcuate guide which serves to hold the door open may be formed by fuseable stop so that, in the event of a fire, the heat causes this locally narrower portion to disappear allowing the door to return to the closed position.

The fuseable stop may be made from an alloy which melts at a suitable temperature, which may be slightly less than the boiling point of water.

Preferably, each guide consists of a slot cut in a plate adapted to be fitted in the threshold and then conveniently each guide follower is in the form of a wheel, preferably a wheel with a hard rim and a hard boss, and an annular body of rubber or elastomeric plastics material between the boss and the rim.

Such a guide slot will tend to follow a circular arc centered about a hinge point defined at the end of the other slot, but near one or other end the slot can be locally narrower, than that required to accommodate the free diameter of the wheel, which thus has to be deformed to get past the local point to reach the latch position at the end of the slot.

The two guides can be modified so that the force necessary to open the door in one direction can be increased by the addition on one or other side of a fuseable stop at the point of local narrowing of the arcuate guide. In this way the door can be given a normal mode of opening in one direction with the possibility of being opened in the other direction in the case of emergency by the application of a greater force. Furthermore, there can be an open door holding position for opening in one direction, but not in the other.

The invention includes the hinge both as supplied with the components ready for fitting on a door and on a door frame and when so fitted with the followers in the guides. In particular the invention covers the hinge when assembled with a door, having a top hinge defining a single point through which any rotational axis of the door must pass, the followers being on either side of a vertical plane through the single point and through the door frame.

The invention may be carried into practice in various ways, and one embodiment will now be described by way of example, with reference to the accompanying drawings; in which

Figure 1 is a sketch showing the components of a lower hinge for a door mounting; and

Figure 2 is a plan view of the plate constituting one component of the hinge shown in Figure 1.

The door is mounted to turn in either direction from a closed position about alternative hinge axes each of which pass through a common central point at the top, defined by a hinge (not shown), and a lower hinge point defined by a wheel 11 arranged to turn about a vertical axis 12 mounted on the underside of the door 13, and one end of an arcuate groove 14 in a plate 15 sunk into the threshold of the door frame. The two hinge axes which meet at the common point at the top, are on either side of a vertical plane through that common point, and through the door frame. As the door opens, one of the wheels 11 will be fixed in the end of its guide 14, while the other moves along its guide generally in the direction of one of the arrows 16, all as described in Specification No. 1,482,202.

In the hinge being described, each of the wheels 11 comprises a steel boss, 17, acting as a bearing on a vertical pin 18 depending from the lower edge of the door, and an external steel rim 19 with annular body of rubber 21 between the boss and the rim, so that the wheel can be deformed elastically in relation to the pivot point 18 fixed in relation to the door.

In Figure 2, the wheel 21 is shown at one end of its groove 14, and in that position it acts as a hinge point while the other wheel (not shown in Figure 2) moves along its guide indicated in Figure 2 as 14'. Chain lines shown at 23 are on circular arcs centered about 18, and separated by a distance equal to the free diameter of the wheel. Thus, in the end position, where the wheel 21 is shown in Figure 2, the elastomeric material is not deformed.

However, if the door is to be opened, so that one of the wheels starts to move along its guide 14, the wheel has to be slightly deformed to pass on internal edge 24 defining a local neck in the groove. Some force is required to distort the wheel sufficiently and that is calculated to be sufficient for the door to be held closed in spite of not only the sort of pressure differences across it that would be expected in normal use, but also those arising from a fire spread situation. For the next part of the length of the groove, the width of the groove is the same as the diameter of the wheel, but it is displaced radially towards the pivot point 18 so that the wheel is slightly deformed and movement along the groove is not completely free, and the door cannot swing open too easily.

At the outer edge 25, the groove widens until at 26, the outer edge corresponds with the position of the underformed wheel, so that the next part of the movement of the wheel is free from restraint.

The door can continue to open, until it reaches the edge of the groove at 27, and even if the wheel should strike the end of the groove with some force, it is unlikely that damage will be done because the wheel acts as a shock absorber by virtue of the body of elastomeric material.

Even, if the door is left after someone has gone through, the weight of the door acting to one side

of the mean hinge plane, will allow the door to swing back to the central position with the wheel going back to the inner end of the groove, and it is designed that with a free swing of the door, there is sufficient inertia for the wheel to move past the edges 25 and 24 to be retained in the central closed position.

Movement in the other direction is similar but in that case, there is a fuseable stop 28 near the outer end of the groove. If the door is not fully open through 90° then it will self close, as described above, but after 70° of opening, the wheel 21 has to be deformed to get past the edge 28 to enter the end of the groove. The door cannot then reclose without sufficient force being applied to cause the wheel to deform as it goes back past the edge 28. In that way a door holding open device is provided. The fuseable stop 28 is made from a tin alloy which has a melting point of about 185°C so that the door is released from the open position in the early stages of a fire.

It will be appreciated that it would also be possible to have a safety door which is normally opened one way, but which could be opened the other way in an emergency by use of more than normal force and that could be achieved by making the edge at 24 project inwardly more than is shown in Figure 2 by the addition of a fuseable stop at 29, so that quite a substantial force would be needed to deform the wheel before it could start to move along its guide 14.

Although the invention has been described with the plate and the guide follower being respectively in the threshold and in the bottom of the door, it is clear that they could be positioned the other way around the plate in the bottom of the door, and the follower in the threshold. Again for a swing door with a bottom some distance above the floor, the two components could be respectively on a door post and on the inner edge of the door with the plate defining a horizontal surface for the arcuate guides.

Claims

1. A hinge for a door mounting comprising a plate having an arcuate guide, and a guide follower, arranged to be mounted one in relation to a door and the other in relation to a door frame, the follower being at least partly of elastomeric material and being of a size to need to be elastically deformed at certain parts of the guide.

2. A hinge as claimed in Claim 1 in which the plate has a pair of arcuate guides, each centered about a point on the other guide, and there are a pair of followers, each adapted to move along one guide while the other is located in relation to the other guide, and defines a hinge point.

3. A hinge as claimed in Claim 2 in which each of the followers is at least partly of elastomeric material.

4. A hinge as claimed in any preceding claim in which the, or each, guide has a locally narrower portion at one, or each end, so that the follower requires to be deformed to move from the end of the guide.

5. A hinge as claimed in Claim 4 in which the locally narrower portion of the arcuate guide is formed by fuseable stop.

5 6. A hinge as claimed in any preceding claim in which the, or each guide consists of a slot cut in a plate adapted to be fitted in the threshold.

7. A hinge as claimed in Claim 6 in which the, or each, guide follower is in the form of a wheel.

10 8. A hinge as claimed in Claim 7, in which each wheel has a hard rim and a hard boss, and an annular body of rubber or elastomeric plastics material between the boss and the rim.

15 9. A hinge as claimed in Claim 7 or Claim 8 in which near one end of the, or each guide slot, the slot is locally narrower than that required to accommodate the free diameter of the wheel, which thus has to be deformed to get past the local point to reach a latch position at the end of the slot.

20 10. A hinge as claimed in Claim 5 or Claim 9 in which the fuseable stop is at one, or other, side of

the groove at the point of local narrowing.

25 11. A hinge constructed and arranged substantially as herein specifically described, with reference to the accompanying drawings.

30 12. A hinge as claimed in any preceding claim, assembled with a door, having a top hinge defining a single point through which any rotational axis of the door must pass, the followers being on either side of a vertical plane through the single point and through the door frame.

35 13. A hinge as claimed in any of Claims 1—12 assembled with a door and frame in which either the plate or the follower is mounted in the threshold of the door, the other of which is mounted in the bottom of the door.

40 14. A hinge as claimed in any of Claims 1—12 assembled with a door and frame in which the plate and the follower are mounted in the vertical frame and the side post of the door.